

# DISHWASHER SERVICE MANUAL



## FREESTANDING ( SERIES X )



Information sheet.....	2
Barcode sticker code explanation.....	3
Electrical components.....	4
Washing specifications and programs.....	10
Child lock .....	13
Water hardness set.....	13
Rinse aid level set.....	15
Service test.....	16
Service failure codes.....	17
Failure routines.....	18
End test program.....	19
Measurement the water hardness.....	20
Failure codes (possible problems).....	21
Poor drying.....	24
Necessary information have to be given to users while installing the dishwasher.....	25
Repair techniques components and resistance values .....	26
Component values measurement.....	27
Disassembly.....	40

**BARCODE STICKER CODE EXPLANATION / DISHWASHER:**

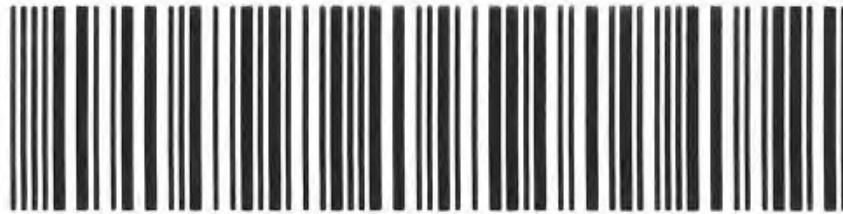

**SN:04668316002054580001**

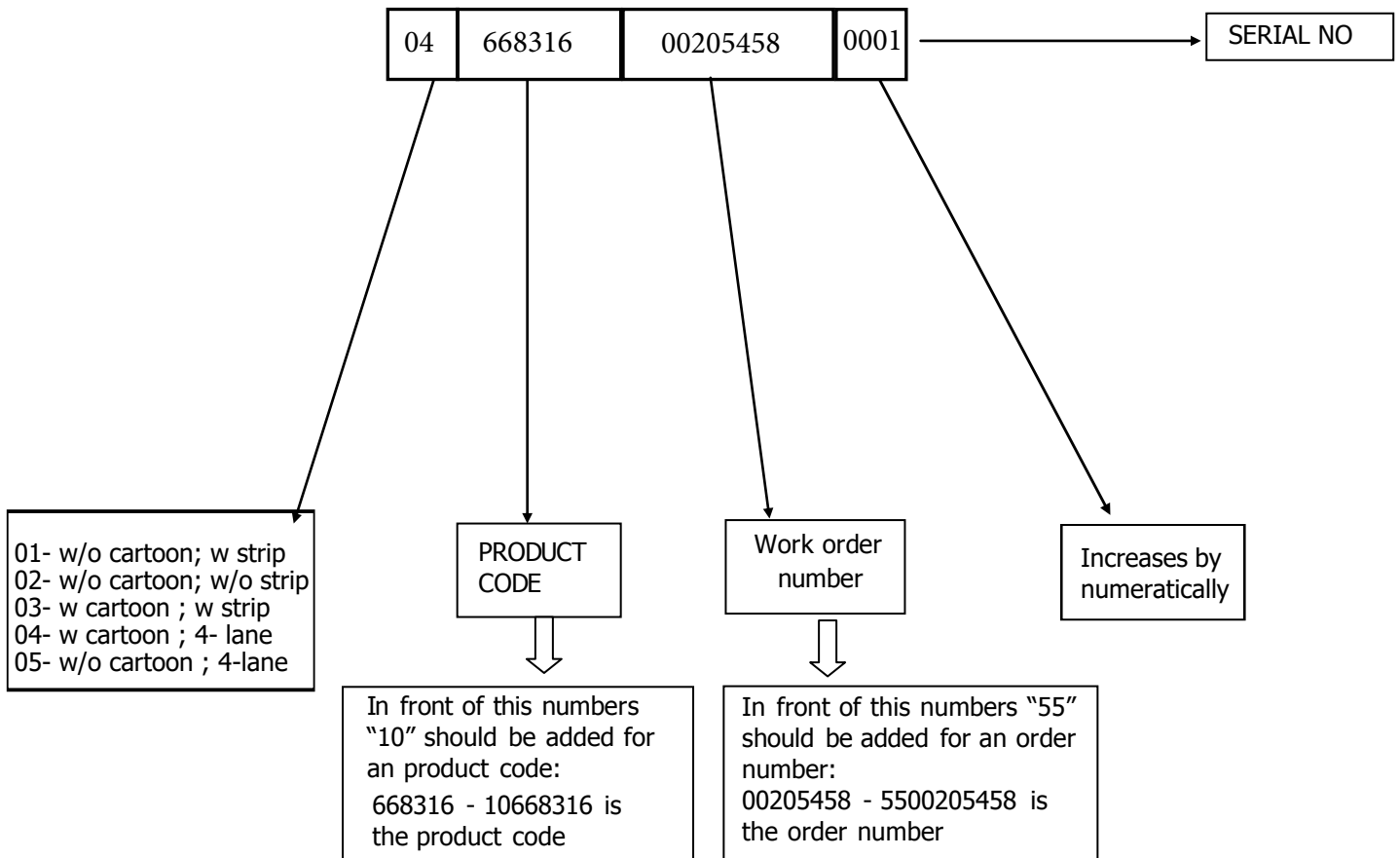

## TOOLS FOR DISASSEMBLE



### Phillips screwdriver

- \*All kinds of star-head screws,
- \*in the phillips screws of the internal components,



### Plier

- \*It is used to bend all kinds of sheet metal ends.



### Multimeter

- \*Resistance values of all kinds of internal components,
- \*Electronic card resistors,
- \*It is used to measure the resistance of display cards.



### **Flat Screwdriver**

It is used to remove all kinds of aesthetic parts (side panels, front panels and external aesthetic parts of the machine).



### **Side Cutter**

It is used to cut cables of internal components or any hard part.



### **Chargeable Drill**

It is the most important tool used to remove and install all kinds of screws in the machine.

# ELECTRICAL COMPONENTS

## BUTTON ( ON / OFF SWITCH )

Button is assembled in the control panel unit. ON /OFF (two pole)

Voltage 250 V  
 Currency 16 (4 )  
 A

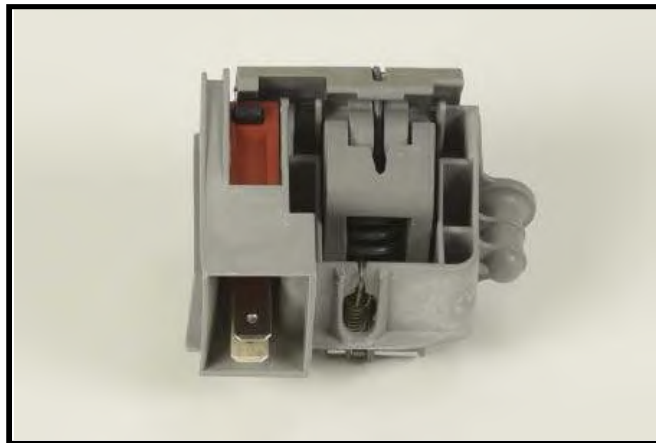
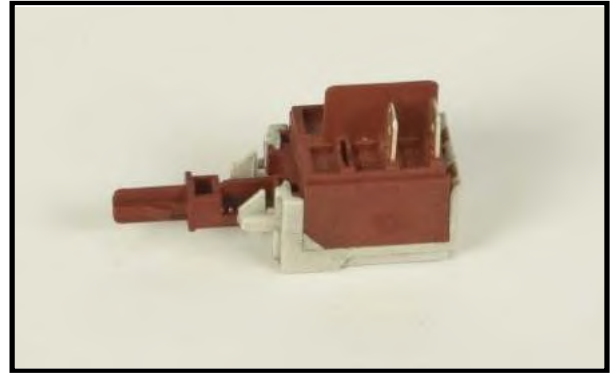

## DOOR LOCK

It is a mechanical lock/release system that is closing the door, supplying the connection of electrical parts in the machine and cutting off the connection.

Currency 16 (4 ) A

## CIRCULATION PUMP

Voltage	220/240
Frequency	50HZ
Total Power	90W
Coil Isolation Class	F
Thermal Protector	150°C
Pump Outlet Pressure	300mbar
Pump Flowrate	60 lt/min

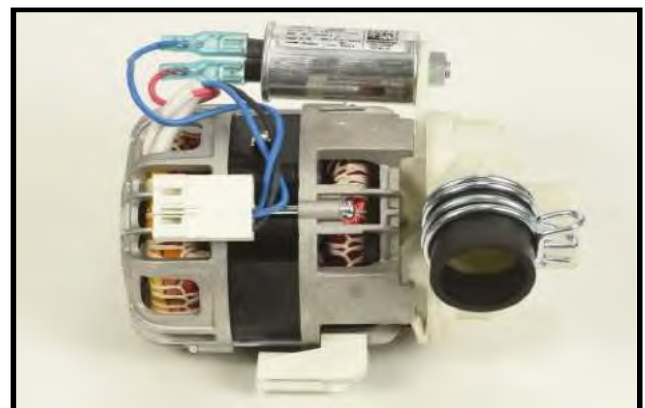

Single direction, single phase, asynchronous and two pole.

It turns opposite clock direction.

It is assembled to the basement with rubber hangers.

Measurement of the primary windings of the washing pump(118.2-135.9 Ω)

Measurement of the secondary windings of the washing pump (white cable – blue cable)(117.9-135.6 Ω)

## FLOATER



		C	T	
FLOATER	CN2.1 - CN 2.5	0 Ω	KN2.5 - KN 2.10	0 Ω
(MICROSWITCH)	CN2.1 - CN 2.4	∞Ω	KN2.4 - KN 2.5	∞Ω
				Microswitch is inactive (no water ) microswitch is active (there is water)

## CAPACITOR

2,5  $\mu$ F - 450 V class S2

Capacitor is permanently connected to the circulation pump coils.

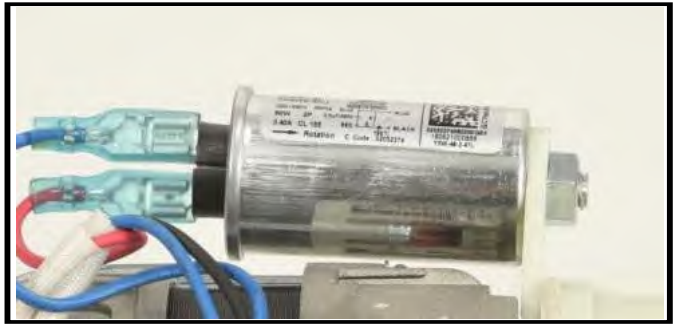

## DRAIN PUMP

Voltage	220/240 volt
Frequency	50Hz
Flowrate	30W
Coil Resistance / Hanyu	220 $\Omega$ % $\pm$ 7
Coil Resistance / Leili	141 $\Omega$ % $\pm$ 7
Coil Isolation Class	F
Thermal Protector	120 $^{\circ}$ C

## HEATER

Voltage 220/240 volt

Total power

1800W 27.6-30.6 ohm

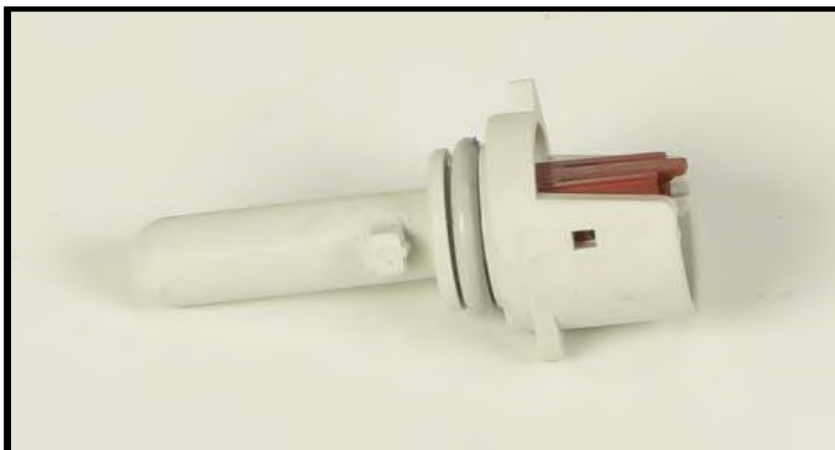
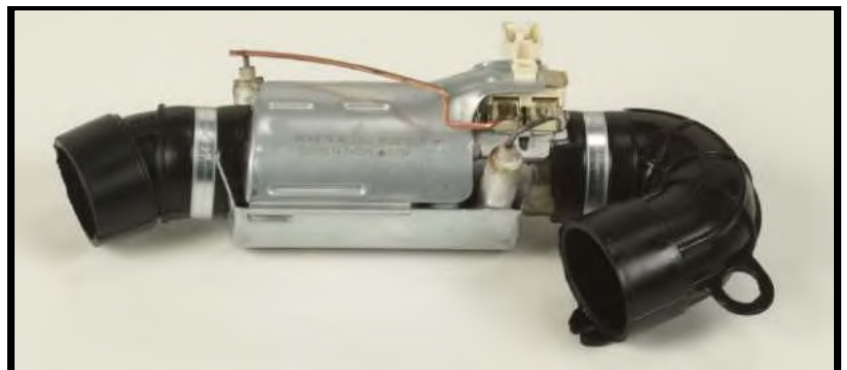

## NTC

+25 $^{\circ}$ C	-	47.200	$\pm$	850 $\Omega$
+30 $^{\circ}$ C	-	37.500	$\pm$	675 $\Omega$
+40 $^{\circ}$ C	-	24.900	$\pm$	349 $\Omega$
+50 $^{\circ}$ C	-	17.000	$\pm$	170 $\Omega$
+60 $^{\circ}$ C	-	11.700	$\pm$	117 $\Omega$
+70 $^{\circ}$ C	-	8.280	$\pm$	108 $\Omega$
+80 $^{\circ}$ C	-	5.945	$\pm$	101 $\Omega$

## PRESSURE SWITCH

Voltage 220/240 v

Frequency 50/60 Hz 16 A

- 3 Pins

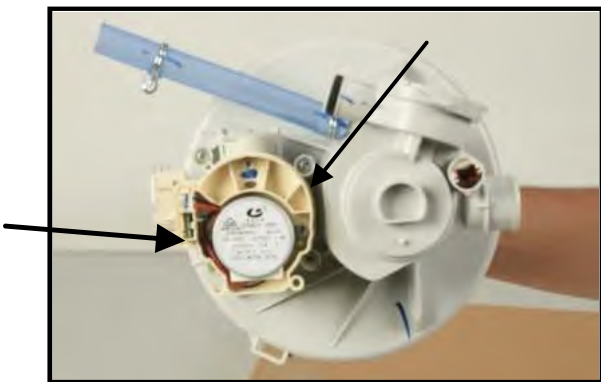
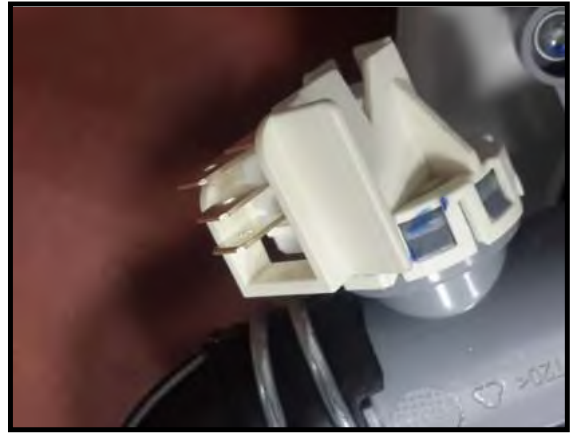

## DIVERTER

There is diverter at freestanding models It is assembled to the Heater Casing Group.

Voltage	220/240 V
Frequency	50 Hz
Power	8W
Resistance	10500 ± %5 Ω

## WATER INLET VALVE

Single inlet and single outlet standard single coil solenoid valve.

Voltage	220 - 240
Total Power	6W
Flowrate	2,5 ±% 15 lt/dk
Coil Isolation Class	H
Resistance	4200 ±%10



It is assembled to the basement and connect to the airbreak by hose.

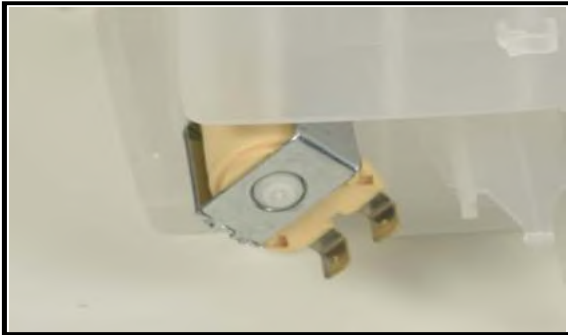
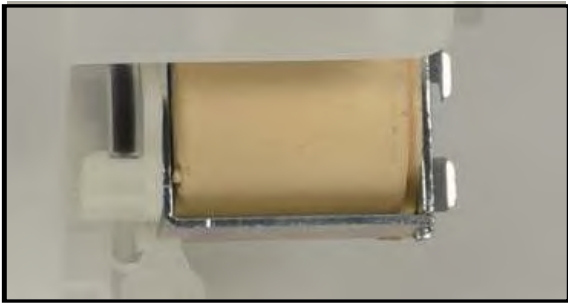

## REGENERATION VALVE

Voltage	220/240 V
Frequency	50/60 Hz
Total power	6 W
Resistance	$3560 \pm \% 10 \Omega^{\circ}\text{C}$

Regeneration valve is assembled on the water softener.

## PARASITE FILTER

Voltage	220/240
Frequency	50/60 Hz

$0,1 \mu\text{F (X1)} + 2 \times 2,2 \mu\text{F (Y2)} + 1\text{M}\Omega$

It is used to prevent parasites from the main supply. It has been assembled to basement.

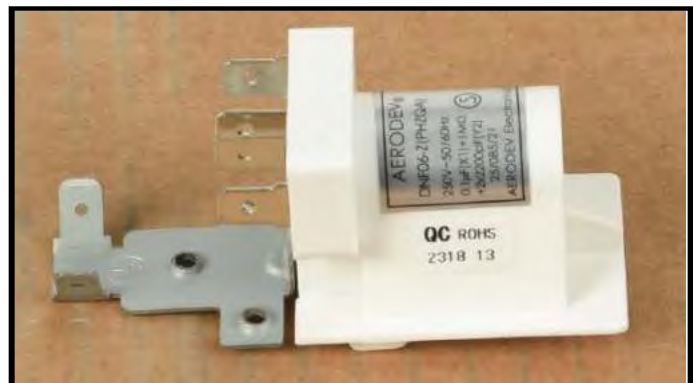

## TURBO FAN MOTOR

There is a thermal protector shaded pole motor, two pole temperature is between  $-40-150^{\circ}\text{C}$

Turbo fan resistance value:  $265 \pm \%10 \Omega$  (The resistance of the turbo fan is measured with the resistor switch).



## SALT SENSOR

Voltage	250 V
Current	50 mA

It is assembled to the water softener.  
It warns if the salt is less than requested quantity.



## POWER CORD

Type	Equip 300-1mm <sup>2</sup> - copper conducting
Isolation	TS-8750-0-500-1-F
Plug	TS-11873058M - 2PNC Injected
Length	1250mm

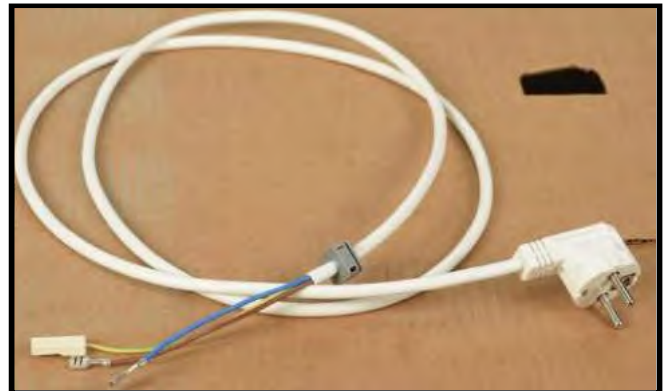

## DRAIN HOSE

Drain hose maximum height	110 cm
Drain hose minimum height	50 cm
Drain hose maximum length	400 cm
Total Power	15 W
Voltage	220/240 V
Frequency	50 Hz
Resistance	238.6± %5 Ω

## UPPER SPRAY ARM

It distributes water from upper spray arm to dirty dishes in the upper basket. It provides to wash the dishes in the upper basket through turning by the holes with various angles.



## LOWER SPRAY ARM

It distributes water from lower spray arm to dirty dishes in the lower basket. It provides to wash the dishes in the lower basket through turning by the holes with various angles.



## DETERGENT / RINSE AID DISPANSER

Detergant dispenser consists of rinse aid and detergent compartment. It has been assembled to the inner door by the snap fits. Only one bobbin has been used for operation the system.

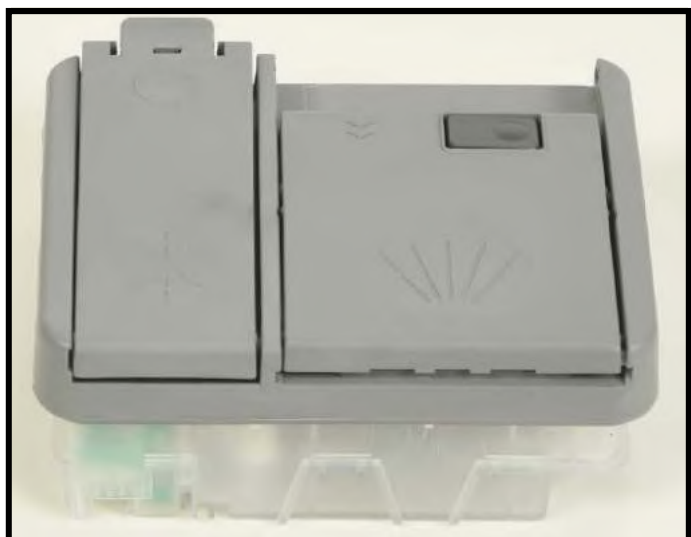

## PROGRAMS

MODEL	PREWASH	QUICK 30	ECO 50	SUPER 50	DELICATE 40	INTENSIVE 65	HYGIENNE 70	GLASS 19'	Glass 29'	14'
X11			X			X				
X12			X	X		X				
X13		X	X	X		X				
X14		X	X	X		X	X			
X15	X	X	X	X		X	X			
X16	X	X	X	X	X	X	X			
X14_5			X	X				X	X	X

### SELECTING AND STARTING PROGRAM AT POWER ON (BEFORE PROGRAM STARTS):

COMMANDS	S/P	Wash	Rinse (with display)	Dry	End
Select program	ON	OFF	OFF	OFF	OFF
Pressure of S/P button	OFF	ON	OFF	OFF	OFF

0 Program duration is shown on display

### OPENING AND CLOSING DOOR (BEFORE PROGRAM STARTS):

COMMANDS	S/P	Wash	Rinse (with display)	Dry	End
Door open	ON	OFF	OFF	OFF	OFF
Door closed	ON	OFF	OFF	OFF	OFF

### OPENING AND CLOSING DOOR DURING PROGRAM (NOT IN DRY STEPS)

During the program if the door is opened and re closed without any modifications at the program button and without the pressure of S/P button, the program continues. Washing program re starts after 8 if the measured temperature is equal or more than 45°C

COMMANDS	S/P	Wash	Rinse (with display)	Dry	End
DDoor open	Blink	ON	OFF	OFF	OFF
DDoor closed	OFF	ON	OFF	OFF	OFF

### OPENING AND CLOSING DOOR DURING PROGRAM (IN DRY STEPS):

During dry step: if the door is opened and re-closed, the program is ended.

COMMANDS	S/P	Wash	Dry	End
Door open	Blink	OFF	ON	OFF
Door closed	OFF	OFF	OFF	ON

### OPENING AND CLOSING DOOR DURING PROGRAM (IN DRY STEPS) WITH DISPLAY:

During dry step: if the door is opened and re-closed, the program is continued.

COMMANDS	S/P	Wash	Rinse (with display)	Dry	End
Door open	Blink	OFF	OFF	ON	OFF
Door closed	OFF	OFF	OFF	ON	OFF

**OPENING AND CLOSING DOOR DURING PROGRAM (IN REGENERATION FIRST STEP):**

During regeneration and resin washing step: if the door is opened and re-closed, the program continues.

COMMANDS	S/P	Wash	Rinse (with display)	Dry	End
Door open	Blink	OFF	OFF	ON	OFF
Door closed	OFF	OFF	OFF	ON	OFF

**OPENING AND CLOSING DOOR DURING PROGRAM (IN REGENERATION SECOND STEP):**

During regeneration and resin washing step: if the door is opened and re-closed, the program is ended.

COMMANDS	S/P	Wash	Rinse (with display)	Dry	End
Door open	Blink	OFF	OFF	ON	OFF
Door closed	OFF	OFF	OFF	OFF	ON

**SELECTING AND STARTING PROGRAM AT DOOR OPENED (BEFORE PROGRAM STARTS):**

COMMANDS	S/P	Wash	Rinse (with display)	Dry	End
Switch on	ON	OFF	OFF	OFF	OFF
Door open	ON	OFF	OFF	OFF	OFF
Select program	ON	OFF	OFF	OFF	OFF

**TERMINATION OF A PROGRAM (END OF PROGRAM):**

COMMANDS	S/P	Wash	Rinse (with display)	Dry	End
End of program	OFF	OFF	OFF	OFF	ON

- Only one digit "0" is shown on display

**CANCELING OF A PROGRAM (DURING PROGRAM):**

COMMANDS	S/P	Wash	Dry	End
Pressure of S/P button 3"	ON	OFF	ON	OFF
End of program	OFF	OFF	OFF	ON

**CANCELING OF A PROGRAM (DURING PROGRAM) WITH DISPLAY:**

COMMANDS	S/P	Wash	Rinse (with display)	Dry	End
Pressure of S/P button 3"	ON	OFF	OFF	ON	OFF
End of program	OFF	OFF	OFF	OFF	ON

- Display shows "1" during cancelation process.
- Display shows only one digit "0" at the end of the cancelation process

**IF THE USERS PRESS THE PROGRAM BUTTON OR PRESS ANY BUTTON (AT THE END OF PROGRAM):**

COMMANDS	S/P	Wash	Rinse (with display)	Dry	End
End of program	OFF	OFF	OFF	OFF	ON
Selection of new program or pressed option	ON	OFF	OFF	OFF	OFF
Pressure of S/P button	OFF	ON	OFF	OFF	OFF

- Display shows selected program duration

### MODIFICATION OF A PROGRAM WITHOUT RESET:

COMMANDS	S/P	Wash	Dry	End
Washing cycle is in progress	OFF	ON	OFF	OFF
Pressure of S/P button	Blink	ON	OFF	OFF
Select new program	Blink	ON	OFF	OFF
Pressure of S/P button	OFF	ON	OFF	OFF

### MODIFICATION OF A PROGRAM WITHOUT RESET (WITH DISPLAY):

COMMANDS	S/P	Wash	Rinse (with display)	Dry	End
Washing cycle is in progress	OFF	ON/OFF	ON/OFF	ON/OFF	OFF
Pressure of S/P button	Blink	ON/OFF	ON/OFF	ON/OFF	OFF
Select new program	Blink	ON/OFF	ON/OFF	ON/OFF	OFF
Pressure of S/P button	OFF	ON/OFF	ON/OFF	ON/OFF	OFF

The program continues with the flow program but with the parameters (temperature, times) of the new program. In heating step: If temperature is over than the new desired temperature cut off of heating step and go on with the next step with new parameters.

If temperature is lower than the new desired temperature heat up water to the desired temperature level.

In washing step: If the washing duration is over than the new program washing duration cut off washing step and go on with next step of new program.

If the washing duration is lower than the new program washing duration go on with washing step.

When new program is selected, display duration is changed to same step of new program

### MODIFICATION OF A PROGRAM WITH RESET:

COMMANDS	S/P	Wash	Rinse (with display)	Dry	End
Washing cycle is in progress	OFF	ON/OFF	ON/OFF	ON/OFF	OFF
Pressure of S/P button 3"	OFF	OFF	OFF	ON	OFF
Drain of water	OFF	OFF	OFF	ON	OFF
End of Drain	OFF	OFF	OFF	OFF	ON
Select new program	ON	OFF	OFF	OFF	OFF

### SWITCH OF THE MACHINE DURING PROGRAM AND BEFORE STARTING

**PROGRAM** When knob of machine is change to Power OFF position during stand by. All leds are OFF

COMMANDS	S/P	Wash	Rinse (with display)	Dry	End
Before starting program	ON	OFF	OFF	OFF	OFF
Change to knob to "POWER OFF"	OFF	OFF	OFF	OFF	OFF
Select new program	ON	OFF	OFF	OFF	OFF
Pressure of S/P button	OFF	ON	OFF	OFF	OFF

When knob of machine is change to Power OFF position during stand by. All leds are OFF, display is OFF, Program is paused and All electrical components are stopped. After changing the knob to any program, before selected program is resumed

COMMANDS	S/P	Wash	Rinse (with display)	Dry	End
Washing cycle is in progress	OFF	ON/OFF	ON/OFF	OFF	OFF
Change to knob to "POWER OFF"	OFF	OFF	OFF	OFF	OFF
Select new program	OFF	ON/OFF	ON/OFF	OFF	OFF
Pressure of S/P button	Blink	ON/OFF	ON/OFF	OFF	OFF
Pressure of S/P button again	OFF	ON/OFF	ON/OFF	OFF	OFF

**CHILD LOCK (WITH DISPLAY):**

Child lock is enable/disabled by contemporary pressure of "+" and "-" buttons on the display card for 3". When lock is enabled, all leds are blink and Display shows "CL" once  
 When lock is disabled, all leds are blink and Display shows "CL" twice  
 When lock is enabled and a button is touched, all leds are blink and Display shows "CL" twice

**WATER HARDNESS SET**

Only service can execute this procedure. This procedure erases the cycle counter.

- Select "POWER OFF" and pressure S/P button

1	FIX	OFF	OFF
2	OFF	FIX	OFF
3	OFF	OFF	FIX
4	FIX	FIX	OFF
5	FIX	OFF	FIX
6	OFF	FIX	FIX

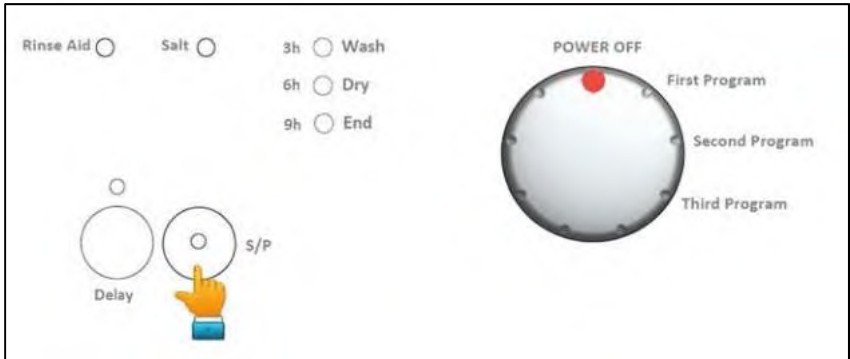

- Select first program and continue press S/P button at least for 5".

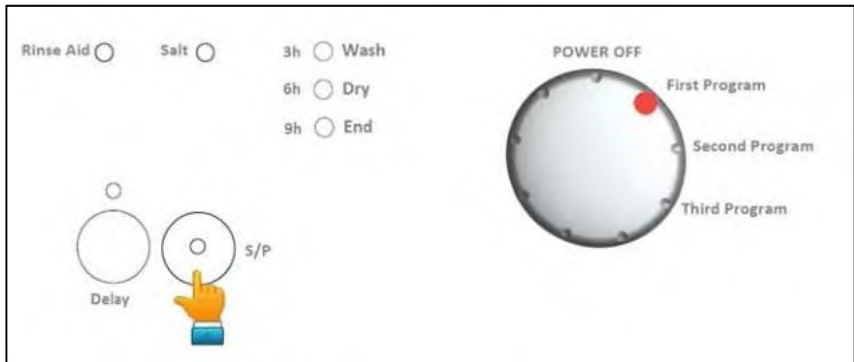

- If "Hardness set" is recognized all leds blink once for 2".
- Release S/P button. The last setting level is viewed\*. (factory setting = level3)

- “SL” is shown on display for 2” (with display model)

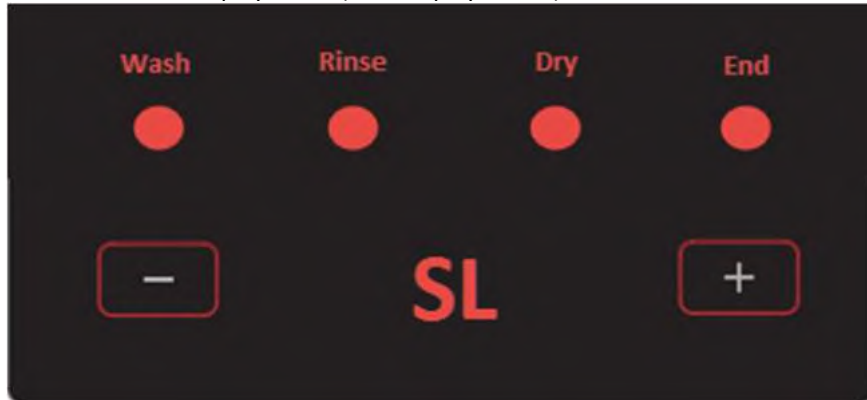

- The last setting level is viewed\*. (factory setting = L03)

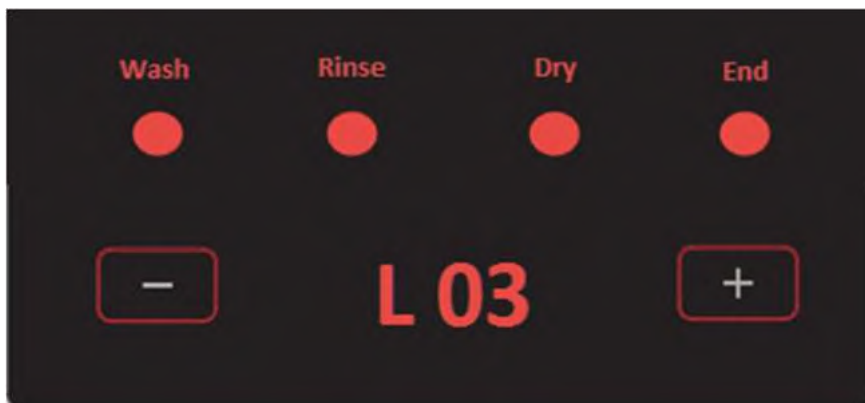

- User can adjust desired level with pushing “+” and “-” buttons ((with display model)

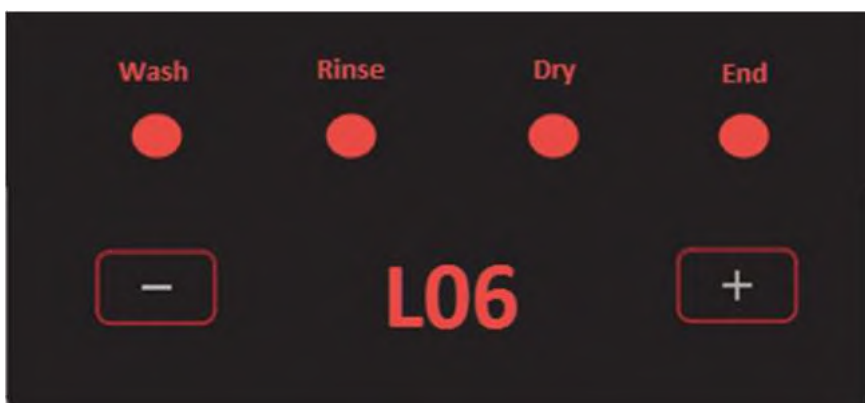

- Pressure S/P to set the desired level
- Hardness level 1 does not return after hardness level 6.
- Turn the knob to “POWER OFF” position to record last selected level and escape water hardness level
- If it is the first hardness set, hardness level is level 3.
- Water hardness cannot be adjusted while any program is running

## RINSE AID LEVEL SET

While machine is off, press Start/Pause button. Select 7<sup>th</sup> position of knob. Continue to press Start/Pause button for 5". Then, rinse aid level set will be recognized and "rA" will shown on display. If model has not display, all leds blink twice to show rinse aid set is recognized.

Default rinse aid level is 4 which corresponds to 4,5 cc.

If the rinse aid tank is empty and user sets rinse aid level as 1(0cc), "lack of rinse aid" warning is not shown.

For models without display; rinse aid levels are the same with water hardness levels.

Level	Wash	End	S/P
1(0cc)	FIX	OFF	OFF
2(1,5cc)	OFF	FIX	OFF
3(3cc)	OFF	OFF	FIX
4(4,5cc)	FIX	FIX	OFF
5(6cc)	FIX	OFF	FIX

### For models with display;

Level	Display
1(0cc)	r1
2(1,5cc)	r2
3(3cc)	r3
4(4,5cc)	r4
5(6cc)	r5

Sliding dispenser dosages are shown below in detail.

1 rinse aid dosage is performed when dispenser is ON during 8" and OFF during 8". =>1,5cc

2 rinse aid dosages are performed 8" ON-8" OFF-8" ON-8" OFF=>3cc

3 rinse aid dosages are performed 8" ON-8" OFF-8" ON-8" OFF-8" ON-8" OFF=>4,5cc

4 rinse aid dosages are performed 8" ON-8" OFF-8" ON-8" OFF-8" ON-8" OFF-8" ON-8" OFF  
=>6cc

Action		Old		New(Sliding dispenser)	
Detergent cover opening:		5"		0.3"	
Rinse aid dose:	Dose setting:	Manual in the dispenser		Automatic in the software	
	Dose quantity and time to delivery	1 - 1cc	25"ON; 2"OFF; 25"ON For each setting from 1 to 6	1 - 0cc	OFF
		2 - 2cc		2 - 1.5cc	8"ON; 8"OFF
		3 - 3cc		3 - 3cc	8"ON; 8"OFF
		4 - 4cc		4 - 4.5cc	8"ON; 8"OFF
		5 - 5cc		5 - 6cc	8"ON; OFF
		6 - 6cc		n/a	n/a
	Standard dose of rinse aid setting by manufacturer	3 (set by bitron manually)		(4-4,5cc set by software)	

## SERVICE TEST

Only service can execute this procedure.

- Select “POWER OFF” and pressure S/P button

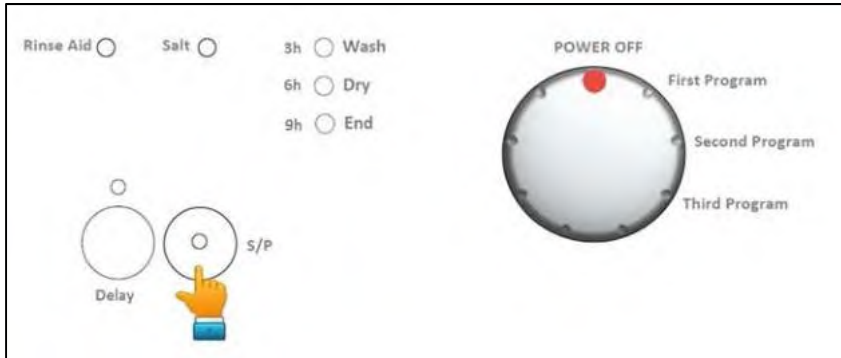

- Select second program and continue press S/P button at least for 5”.

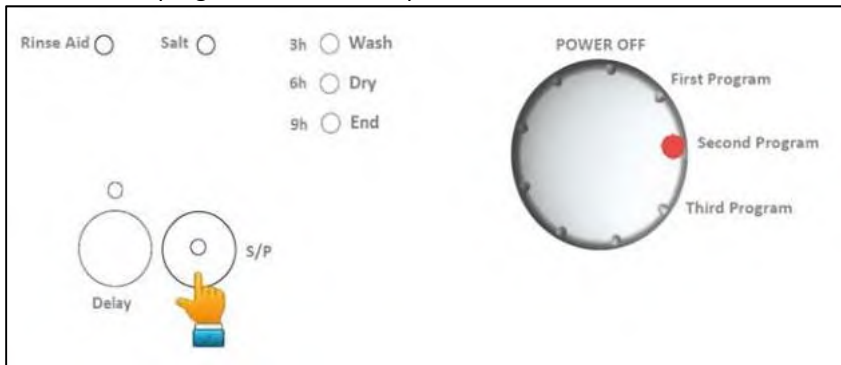

- When “Service test” is recognized all leds are ON and “SP” is shown on the display together without blinking.

If model is without display, all leds blink three times when “Service Test” is recognized.



- Service test starts.
- Turn the knob to “POWER OFF” position to escape service program
- Service test cannot be performed while any program is running

During the first 6” of test, if a failure code is stored in memory, its codification is shown. Error code blinks on display and all leds are OFF.

Also at the end of the test if an error occurs its error code is visualized.

FOR X AND X\_SLIM SERIES AND X\_WP SERIES:

Step	Commands	Time	Tested Load
0	Show code	6"	Before start, the code of last error is visualized (see below)
1	Drain	6"	Drain pump.
2	Fill (2,5l)	~ 1'	Flow meter; Inlet Valve;
3	Fill + Wash (1lt)		Flow meter; Inlet Valve; Pressure Switch;
5	Wash	1'	Circulation pump; Regeneration Valve; detergent dispenser.
6	Wash + Heat ***	5'	Heater (PSW); NTC; diverter (position).
7/8	Reg. Valve	1'	Regeneration Valve
9	Drain	20"	Drain pump; pressure switch.
10	End	-	Code error or end led

FOR X\_WOP SERIES:

Step	Commands	Time	Tested Load
0	Show code	6"	Before start, the code of last error is visualized (see below)
1	Drain	6"	Drain pump.
2	Fill (2,5l)	~ 1'	Flow meter; Inlet Valve;
3	Fill + Wash (1lt)		Flow meter; Inlet Valve;
5	Wash	1'	Circulation pump; Regeneration Valve; detergent dispenser.
6	Wash + Heat ***	5'	Heater (PSW); NTC; diverter (position).
7/8	Reg. Valve	1'	Regeneration Valve
9	Drain	20"	Drain pump; pressure switch.
10	End	-	Code error or end led

In service test the unsuccessful heating failure routine works with reduced time of recognize (first measure at 2'00", second measure at 4'20")

During the service test, the door is opened, start/pause led blinks

During the service test, the start/pause button is pressed, the program corresponding at the knob position starts.

Also at the end of the test if an error occurs its error code is visualized. Turn the knob to "POWER OFF" position to escape failure code.

Also at the end of the test if an error does not occurs any error code is not visualized. Machine will be standby that is selected second program

## SERVICE FAILURE CODES

FOR X AND X\_SLIM SERIES AND X\_WP SERIES:

Name	S_P	Wash	End	display	Notes
Overflow/Leakage	-	Blink	Blink	F0/F1	In the normal work only leakage is visualized.
Drain time out	Blink	-	Blink	F2	
Presence Flow meter impulses	-	-	Blink	F3	
Absence Flow meter imp.	-	Blink	-	F4	In the normal work is not visualized.
Empty Level	Blink	-	-	F5	
Re-Fill time out	Blink	-	-	F5	
NTC ca/cc	Blink	Blink	-	F6	
Overheating	Blink	Blink	-	F7	
Unsuccessful heating	Blink	Blink	-	F8	In the normal work is visualized at the end of prg
Parameter set salt incorrect	Blink	Blink	Blink	SE	In the normal work this failure is not visualized.
CK Parameters	Blink	Blink	Blink	FE	
HIGH/LOW VOLTAGE	Blink	Blink	Blink	HI/LO	

FOR X\_WOP SERIES:

Name	S P	Wash	End	display	Notes
Overflow/Leakage	-	Blink	Blink	F0/F1	In the normal work only leakage is visualized.
Presence Flow meter impulses	-	-	Blink	F3	
Absence Flow meter imp.	-	Blink	-	FF	In the normal work is not visualized.
NTC ca/cc	Blink	Blink	-	F6	
Overheating	Blink	Blink	-	F7	
Unsuccessful heating	Blink	Blink	-	F8	In the normal work is visualized at the end of prg
Parameter set salt incorrect	Blink	Blink	Blink	SE	In the normal work this failure is not visualized.
CK Parameters	Blink	Blink	Blink	FE	
HIGH/LOW VOLTAGE	Blink	Blink	Blink	HI/LO	

**FAILURE ROUTINES**

N°	Name	Exit of failure state	Service Call
1	Switch door open	Door closing	NO
2	Delay after door closing	7" delay before restart prg in heating step	NO
3	Overflow Leakage	Overflow signal gets off OFF/ON	NO ----- YES
4	Draining time out	OFF/ON	YES
5	Presence of Flow meter impulses	Flow Meter signal gets off. OFF/ON.	NO ----- YES
6	Absence of Flow meter impulses	Pressure switch on Full. Pressure switch on Empty. OFF/ON	NO* ----- NO/YES
7	Level Empty	Level doesn't reach full	NO/YES
8	Re-Fill	3 Re – fill in the same washing step	NO/YES
8	NTC ca/cc	OFF/ON	YES
8	Overheating	OFF/ON	YES
10	Unsuccessful heating	OFF/ON	YES
11	Diverter opened	OFF/ON	YES
12	CK Parameters	OFF/ON	YES
13	High Voltage Failure	OFF/ON	YES
14	Low Voltage Failure	OFF/ON	YES

\*Cycle could be executed with a filling time.

If a failure is recognized:

- Stop all devices
- Stop program flow.
- Drain Empty + 30" with circulation pump on

If the failure requires the termination of the washing program:

- Stop all the devices.
- Start to visualize the failure code.

If the failure doesn't require the termination of the washing program:

- Stop all the devices.
- Re-Start the washing program.

If it is necessary it performs the *Re-Fill routine*

**Re-Fill Routine**

After a forced drain (ex: a failure routine) if the dishwasher was in wash before the drain it performs the re-fill routine:

- Inlet Valve ON + circulation pump OFF to load 3l (time out 420")
- When the first load step is finished, Inlet Valve ON + circulation pump ON to load 1l (time out 100")
- Return to the washing cycle

## END TEST PROGRAM

End test is divided in two parts: end test 1 (functionally test) and end test 2 (heating and leakage test).  
End test 1:

Vestel receives the electronic cards ready to start “end test 1”. In any case, it’s possible, re-start the end test 1 with a manual manoeuvre.

- Select “POWER OFF” and pressure S/P button

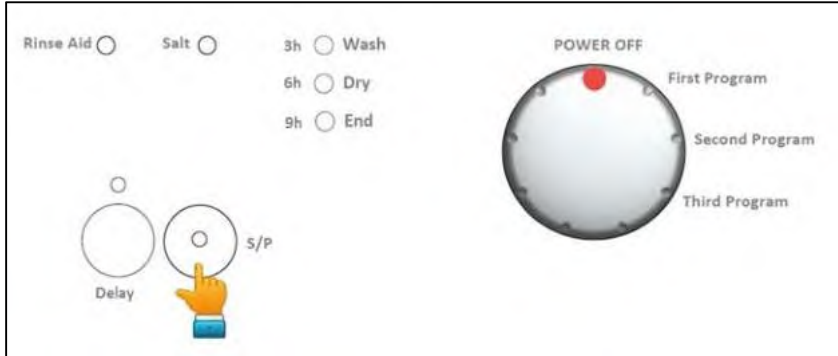

- Select third program and continue press S/P button at least for 3” or more.

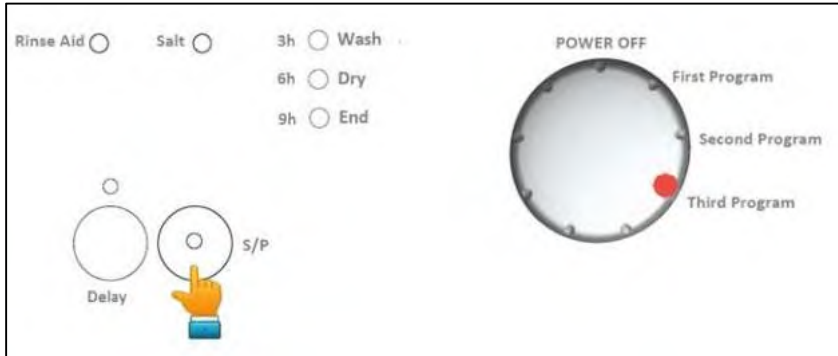

- After 5”, when “End test” is recognized all leds are ON and “EP” is shown on the display together for 2”.
- Next; “188” is shown on the display and all leds are ON together for 2”.



- End test starts.
- When Turn the knob to “POWER OFF” position, End test is not finished.
- After turn the knob to any position without “POWER OFF” End test started again.
- End test cannot be performed while any program is running
- At the end of end test 1, Machine will be stand by and any led is not shined

# MEASUREMENT THE WATER HARDNESS

## TEST STRIP;

The washing effectiveness of your machine depends on the softness of the tap water. For this reason, your machine is equipped with a system that reduces the hardness in mains water supply. The washing effectiveness will increase when the system is correctly set. To make the system setting, use the testing strip, if it is available, and find the hardness of the mains water supply.

Open the testing strip.	Run water through your tap for 1 min.	Keep the testing strip in water for 1 sec.	Shake the testing strip after taking it out of water.	Wait for 1 min.	Make your machine's water hardness setting according to the result obtained through the testing strip.
-------------------------	---------------------------------------	--	---	-----------------	--

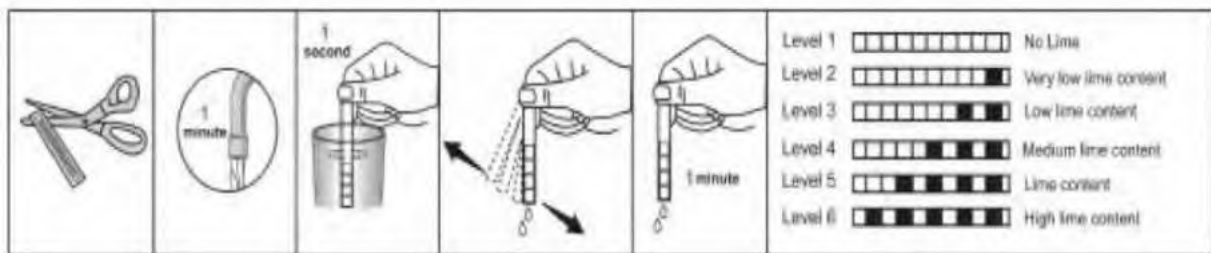

# **FAILURE CODES (Possible Problems)**

## **F1 (ALARM IS ACTIVE FOR OVERFLOW)**

### **FLOATER**

- Floater switch can be out order or have a problem with the cable connection.

### **TUB**

- There can be a water leakage from the tub

### **ELECTRONIC CARD**

- Electronic card can be out of order.

## **F2 (THE WASTE WATER IN THE MACHINE CANNOT BE DISCHARGED)**

### **Drain hose**

- Water outlet hose is clogged
- Check of the water outlet hose position.

### **Drain pump**

- Check the drain pump resistance and power values
- There can be a problem with cable connection of the drain

### **Pressure switch**

- Pressure switch of the heater casing group can have a mechanical or cable connection problem.

## **F3 (ERROR OF CONTINUOUS WATER INPUT)**

### **Water inlet valve**

- Water inlet valve can be out of order or can not be closed.

### **Electronic card**

- Electronic card can be out of order.

## **F4 (FLOWMETER FAULTY)**

### **Flowmeter**

- Flowmeter can be out of order.
- Cable connection of flowmeter can be faulty.

### **Electronic card**

- Electronic card can be out of order.

## **F5 (INADEQUATE WATER SUPPLY)**

### **Water tap**

- Make sure the water input tap is totally open and that there is no water cut.

### **Water inlet hose**

- Close the water input tap, separate the water input hose from the tap and clean the filter at the connection end of the hose.

### **Water inlet valve**

- Water inlet valve filter can be clogged.
- Water inlet valve can be out of order. There can be a problem with the cable connection of water inlet valve.

### **Floater**

- Floater switch can be out of order or have a problem with the cable connection.

### **Pressure switch**

- Pressure switch of the heater can have a mechanical or cable connection problem.

### **Circulation pump**

- Circulation pump can be out of order or have a problem with the cable connection. External part can be blocked to the circulation pump.

## **F6 (NTC FAULTY)**

### **Ntc**

- Ntc can be out of order.
- Ntc cable connection can be faulty. Ntc can be short or open circuit.

### **Electronic card**

- Check the power and resistance value of heater.
- Check the cable connection of the heater.

## **F7 (EXTREME HEATING UP FAULTY)**

### **Ntc**

- If the water temperature inside machine higher than 77°C, ntc can be out of order.

### **Electronic card**

- Electronic card can be out of order.

## **F8 (INADEQUATE HEAT)**

### **Heater**

- Check the power and resistance values.
- Check the cable connection of the heater.

### **Electronic card**

- Check the electronic card

## **F9 (DIVERTER POSITION PROBLEM)**

### **Diverter**

- Check the values of the diverter.
- Check the cable connection of the diverter.

### **Electronic card**

- Check the electronic card

## **FA (TURBIDITY SENSOR FAULTY)**

### **Turbidity sensor**

- There can be some soil around the turbidity sensor.
- Check the cable connection of the turbidity sensor.

### **Electronic card**

- Check the electronic card.

## POOR DRYING

- a) The programme which hasn't got a drying phase; could be selected the customers should be informed about the programmes.
- b) there might be lack of rinse aid compartment.

X series have rinse aid indicator on the control panel.



**There isn't any rinse aid**



**there is rinse aid**

- c) There can be mechanical or electrical problem with the detergent dispenser.
- d) There can be a problem on the PCB card.

# NECESSARY INFORMATION HAVE TO BE GIVEN TO USERS WHILE INSTALLING THE DISHWASHER

Customer should be informed about following items.

- Give general information to user about the product.
- General information about washing programmes and suggest to the customer using suitable program according to the dirtiness level.
- Give information about additional functions.
- Give information to the customer about starting the machine, following the program, resetting the program and changing the program.
- Give information about activate and inactive the child lock. Customers should be informed about the child lock will not be inactive automatically at the end of the programme.

Models haved  $\frac{1}{2}$  half load option;



In  $\frac{1}{2}$  option when only upper Lamp is flashed, only upper spray Will be in operation.



In  $\frac{1}{2}$  option, when only lower lamp is flashed, only lower spray will be On operation.



When both lamps are flashed, this Function is half load function. If the Customers have little amount of Dishes, they should use this function.

**When both lamps are not flashed, It means the machine will continue normal operation. When the lamps are not flashing, does not mean spray arms are not rotating.**

- The customers should be informed about looking at instruction manual at first, when they face to failure.
- After installing the machine to a suitable place, run it unloaded for the first time.

**This should be recommended to the customers that they should search the instruction manual carefully when there is a possible repair.**

# REPAIR TECHNIQUES COMPONENTS AND RESISTANCE VALUES

COMPONENTS	C		T		NOTES
ON / OFF SWITCH	0 Ω on component		0 Ω on component		ON/OFF button is pressed
DOOR SWITCH	CN2.9 - CN2.2 0 Ω		KN2.8 - KN2.10 0 Ω		Door is close
PRESSURE SWITCH	CN2.10 - CN2.2	0 Ω ∞ Ω	KN2.9 - KN2.10	0 Ω ∞ Ω	Full fill water no water
DRAIN PUMP / HANYU	CN2.2 - CN2.4	220 Ω % ±10	KN2.4 - KN2.10	220 Ω % ±10	
DRAIN PUMP / LEILI	CN2.2 - CN2.4	141 Ω % ±10	KN2.4 - KN2.10	141 Ω % ±10	
WATER INLET VALVE	CN2.6 - CN2.9	4200 Ω ± %10 (20°C)	KN2.6 - KN2.8	4200 Ω ± %10 (20°C)	
REGENERATION VALVE	CN2.2 - CN2.7	3560 Ω ± %10(25°C)	KN2.2 - KN2.10	3560 Ω ± %10(25°C)	
SALT SENSOR	CN5.1 - CN5.2	0 Ω NO SALT ∞ Ω THERE IS	KN50.10 - KN 50.11	0 Ω NO SALT ∞ Ω THERE IS SALT	Measure just on the electronic
HEATER	29.1 ± 1,5 Ω		29.1 ± 1,5 Ω		Measure just on the component
DETERGENT DISPENSER	2300 Ω ±%10 (25 C°)		2300 Ω ±%10 (25 C°)		Measure just on the component
CIRCULATION PUMP	CN2.3 - CN2.9		KN2.3 - KN 2.8		Primary winding Secondary winding (from the component)
SET NTC SENSOR	CN 3.2 CN 3.1		KN 50.1 KN 50.2		
FAN MOTOR	CN 6.2 - CN 2.9		KN 6.2 - KN 2.8		
DIVERTER	CN 6.1 - CN 2.9 10500 ± %7 Ω		KN 6.1 - KN 2.8 10500 ± %7 Ω		
RINSE AID SENSOR	CN 5.3 - CN 5.2	0 Ω NO RINSE AID ∞ Ω THERE IS RINSE	KN 50.8 - KN 50.9	0 Ω NO RINSE AID ∞ Ω THERE IS RINSE AID	Rinse aid off Rinse aid on
FLOATER (MICROSWITCH)	CN2.1 - CN 2.5 CN2.1 - CN 2.4	0 Ω ∞ Ω	KN2.5 - KN 2.10 KN2.4 - KN 2.5	0 Ω ∞ Ω	Microswitch is inactive (no water) microswitch is active (there is water)

## MEASURING THE COMPONENTS FROM THE ELECTRICAL CARD

You might measure the components either connectors of electronic card or directly on the component.

Measuring from the connectors of electronic card gives definite result to define the repair. If you know the specialities and values of tester, you can easily determine the repair.



Picture (a)

### Example electronic card

Probes of the tester should be applied on to the related connectors of the electrical card; control the values according to the resistance value table. Picture (a)

# COMPONENT VALUES MEASUREMENT

**Precaution: Always** remove the plug from the power socket before touching internal components.

## WASHING PUMP:

**From the electrical card:**

You can only measure the primary winding value from the electrical card.  
Resistance value of the primary winding must be

	C	T	
CIRCULATION PUMP	CN2.3 - CN2.9	KN2.3 - KN 2.8	Primary winding Secondary winding (from the component)

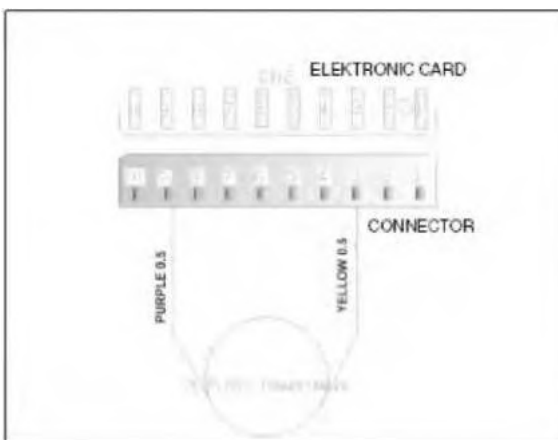

Above sketch show the connectors of the washing pump on the electrical card. Probes of the tester should be applied on to the related connectors.

**From the component:**



Measurement of the primary windings of the washing pump



Measurement of the secondary windings of the washing pump (white cable – blue cable)

Probes of the tester should be applied on to the related connectors as shown on the pictures.

# DRAIN PUMP

From the electrical Card:

	C		T	
DRAIN PUMP / HANYU	CN2.2 - CN2.4	220 Ω % ±10	KN2.4 - KN2.10	220 Ω % ±10
DRAIN PUMP / LEILI	CN2.2 - CN2.4	141 Ω % ±10	KN2.4 - KN2.10	141 Ω % ±10

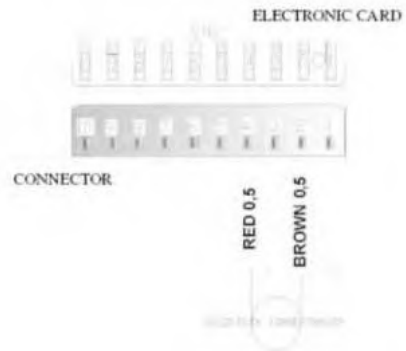

Above sketch show the connectors of the drain pump on the electrical card. Probes of the tester should be applied on to the related connectors.

From the component:



Probes of the tester should be applied on the related connectors as shown on the pictures.

# WATER INLET VALVE

From the electrical Card:

	C	T
WATER INLET VALVE	CN2.6 - CN2.9 4200 Ω ± %10 (20°C)	KN2.6 - KN2.8 4200 Ω ± %10 (20°C)

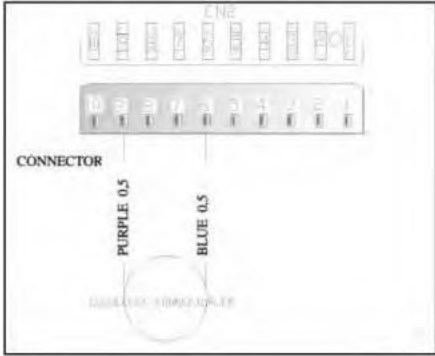

Above sketch show the connectors of the water inlet valve on the electrical card. Probes of the tester should be applies on to the related connectors.

From the component:



Probes of the tester should be applied on to the related connectors as shown on the pictures.

# HEATER

It can't be measured from the electrical card.

From the component:

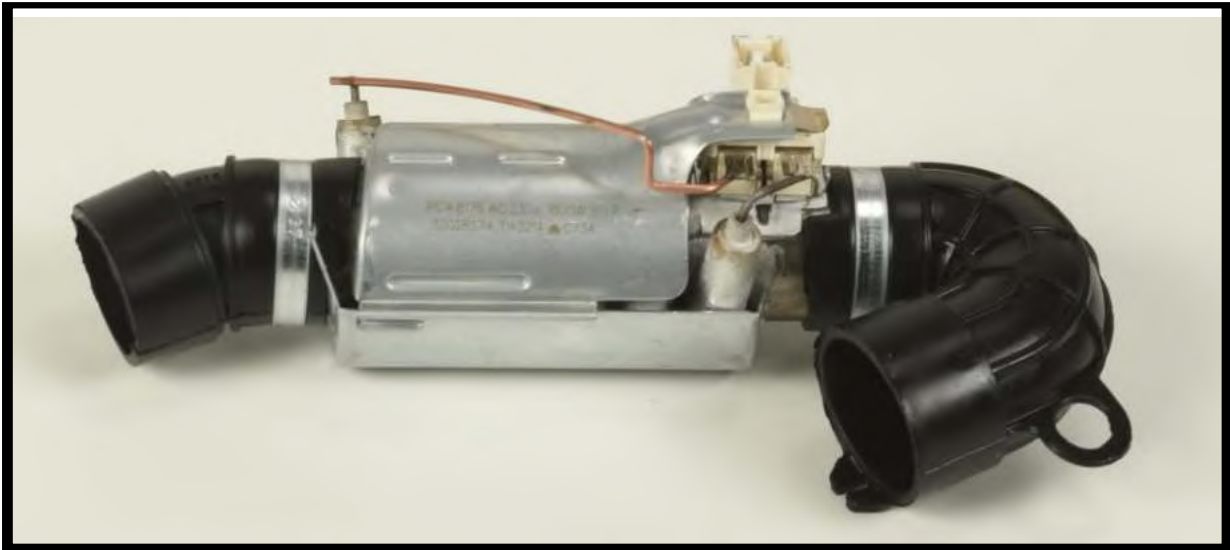

# DETERGENT DISPENSER

It can't be measured from the electrical card:

	C	T
DETERGENT DISPENSER	2300 Ω ±%10 (25 C°)	2300 Ω ±%10 (25 C°)

From the component:

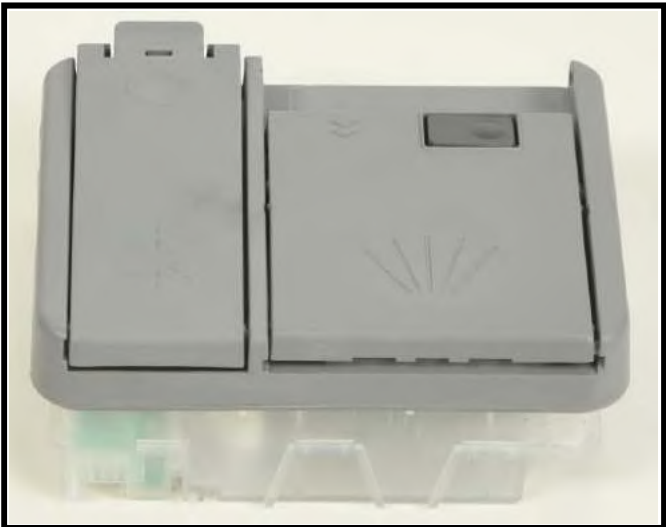

# REGENERATION VALVE

From the electrical Card:

	C	T
REGENERATION VALVE	CN2.2 - CN2.7 3560 Ω ± %10(25°C)	KN2.2 - KN2.10 3560 Ω ± %10(25°C)

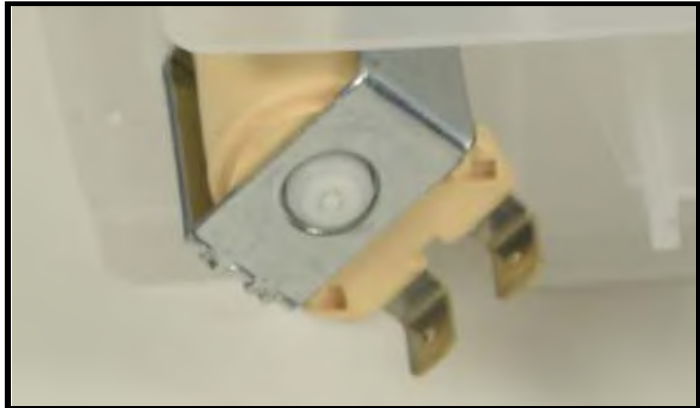
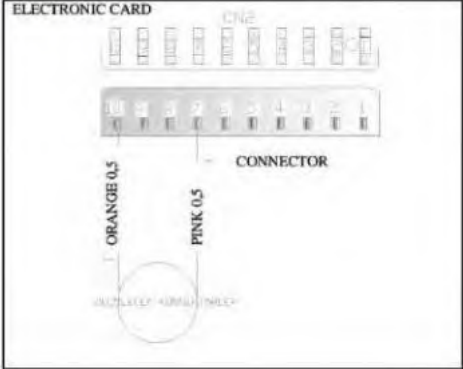

Above sketch show the connectors of the regeneration valve on the electronic card. Probes of the tester should be applied on to the related connectors.

From the component:



## PRESSURE SWITCH

From the electrical card:

PRESSURE SWITCH	C		T		Full fill water & Circulation pump works
	CN2.10-CN2.2	$\infty \Omega$	KN2.9-KN2.10	$\infty \Omega$	
	CN2.10-CN2.2	0 $\Omega$	KN2.9-KN2.10	0 $\Omega$	No water

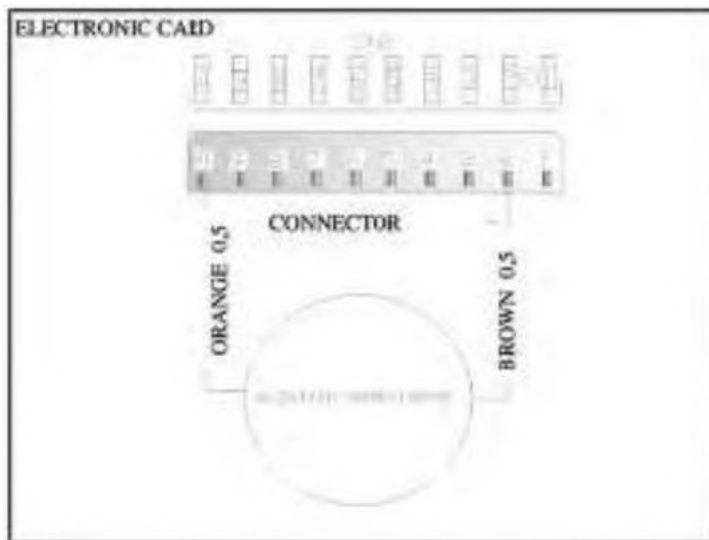

From the component:



Probes of the tester should be applied on to the related connectors as shown in the picture above.

# DIVERTER

From the electrical Card:

	C	T
DIVERTER	CN 6.1 - CN 2.9 10500 ± %7 Ω	KN 6.1 - KN 2.8 10500 ± %7 Ω

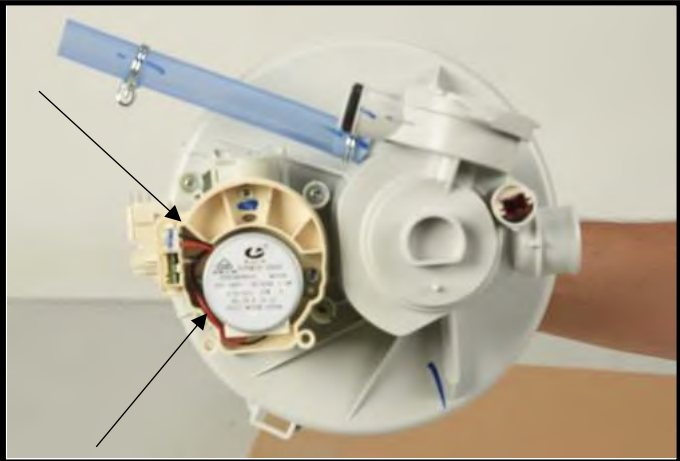
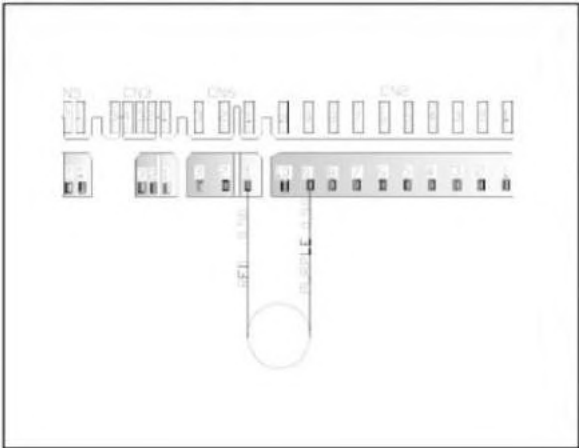

Sketch above show the connectors of the diverter on the electrical card. Probes of the tester should be applied on to the related connectors.

From the component:



Probes of the tester should be applied on to the related connectors as shown on the pictures.

## SALT SENSOR

From the electrical card:

	C	T	
SALT SENSOR	CN5.1 - CN5.2 0 $\Omega$ NO SALT $\infty \Omega$ THERE IS SALT	KN50.10 - KN 50.11 0 $\Omega$ NO SALT $\infty \Omega$ THERE IS SALT	Measure just on the electronic

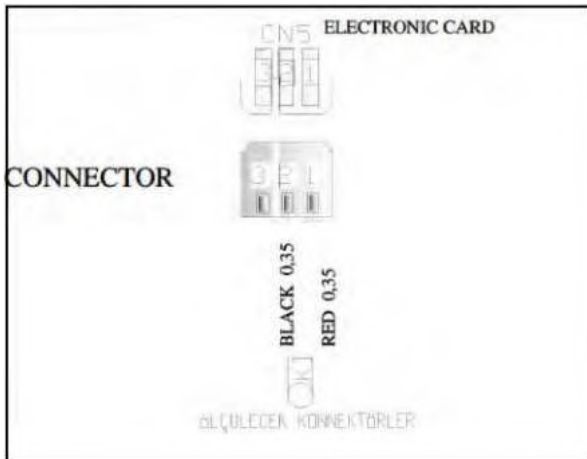

Sketch above show the connectors of the salt sensor on the electrical card. Probes of the tester should be applied on the related connectors.

From the component:



salt sensor can also be measured from the water softener when the salt sensor is assembled on the water softener.

Probes of the tester should be applied on to the related connectors as shown on the pictures.

# FLOATER

From the electrical card:

		C		T	
FLOATER (MICROSWITCH)	CN2.1 - CN 2.5 CN2.1 - CN 2.4	$0\ \Omega$ $\infty\ \Omega$		KN2.5 - KN 2.10 KN2.4 - KN 2.5	$0\ \Omega$ $\infty\ \Omega$ Microswitch is inactive (no water) microswitch is active (there is water)

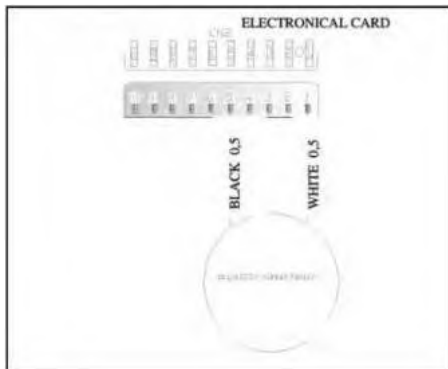
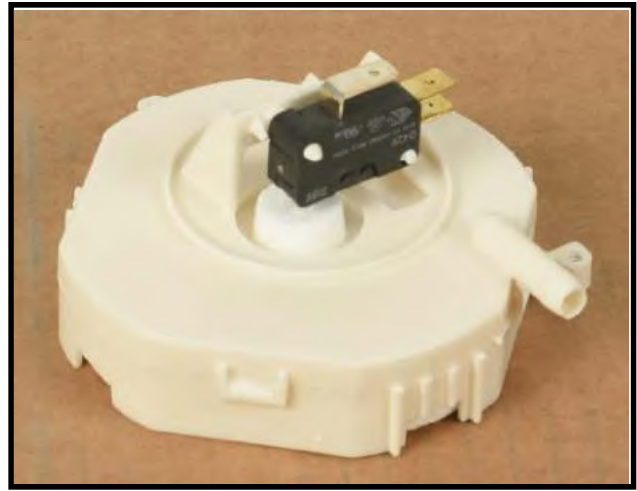
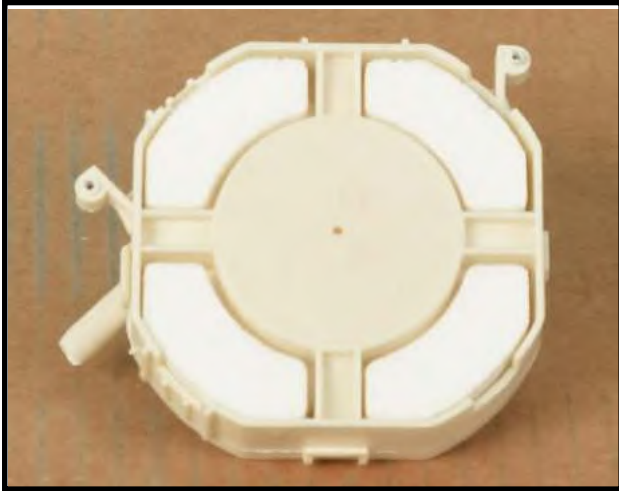

**Position 1 :** You can check the floater by controlling the specified value intervals.

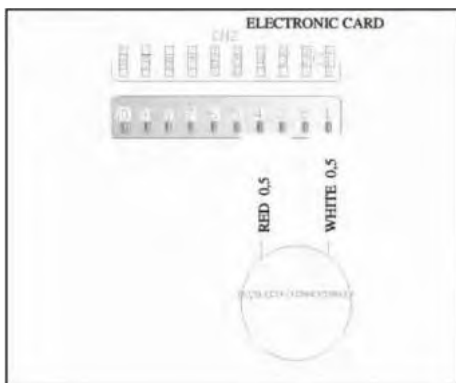

**Position 2 :** If failure code is occurred related with the floater within control the above values: You can figure out whether leakage occurs or not.

# DOOR SWITCH

From the electrical card:

	C	T	
DOOR SWITCH	CN2.9 - CN2.2 0 Ω	KN2.8 - KN2.10 0 Ω	Door is close

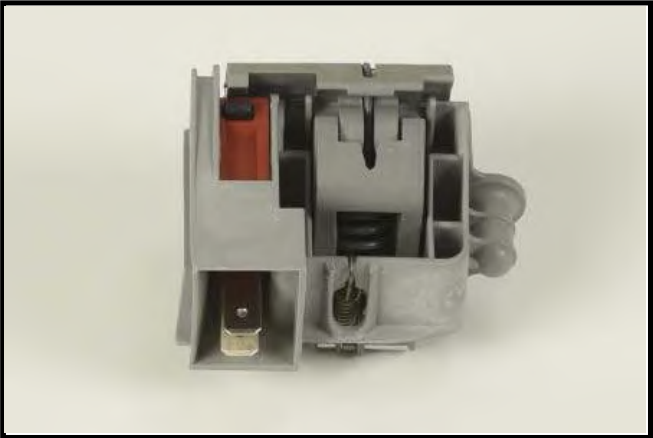
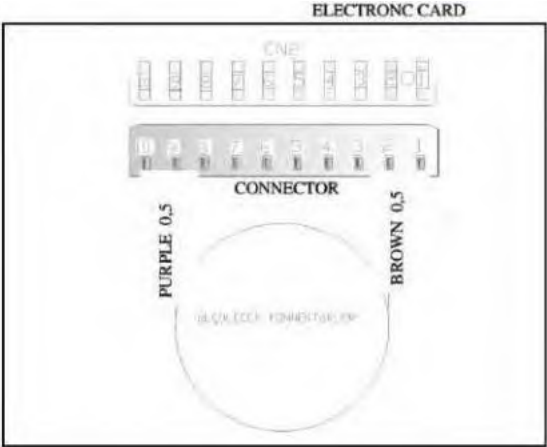

Above sketch show the connectors of the door switch on the electrical card.

From the component:

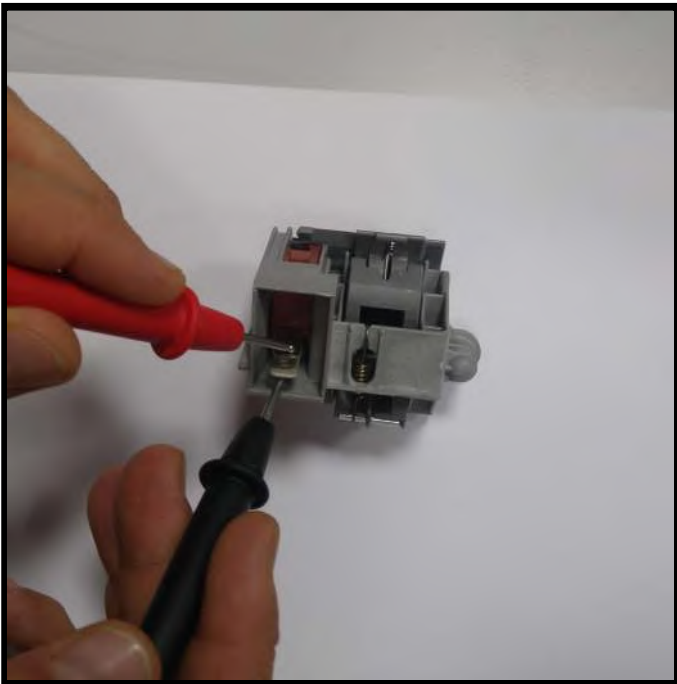

Probes of the tester should be applied on to the related connectors as shown on the pictures.

# FAN MOTOR

From the electrical card:

	C	T
FAN MOTOR	CN 6.2 - CN 2.9	KN 6.2 - KN 2.8

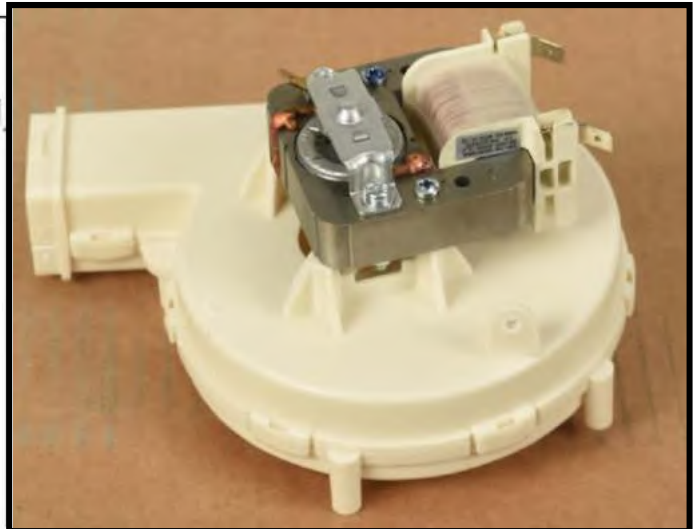
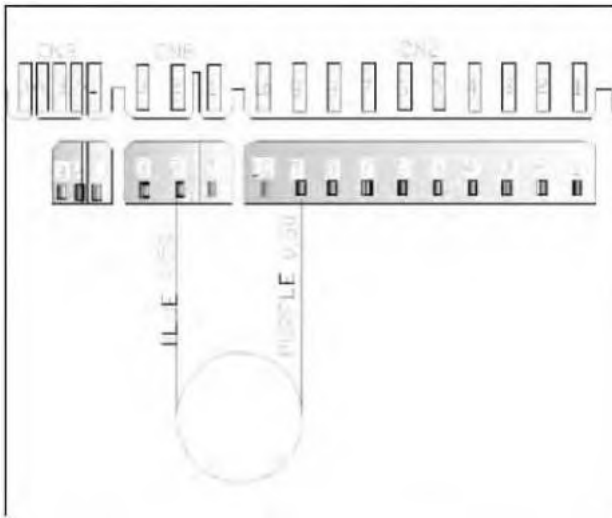

Above sketch shows the connectors of the fan motor on the electrical card.

From the component:



Probes of the tester should be applied on to the related connectors as shown on the pictures.

# RINSE AID SENSOR

From the electronical card:

		C		T	
RINSE AID SENSOR	CN 5.3 - CN 5.2	0 Ω NO RINSE AID ∞ Ω THERE IS RINSE AID	KN 50.8 - KN 50.9	0 Ω NO RINSE AID ∞ Ω THERE IS RINSE AID	Rinse aid off Rinse aid on

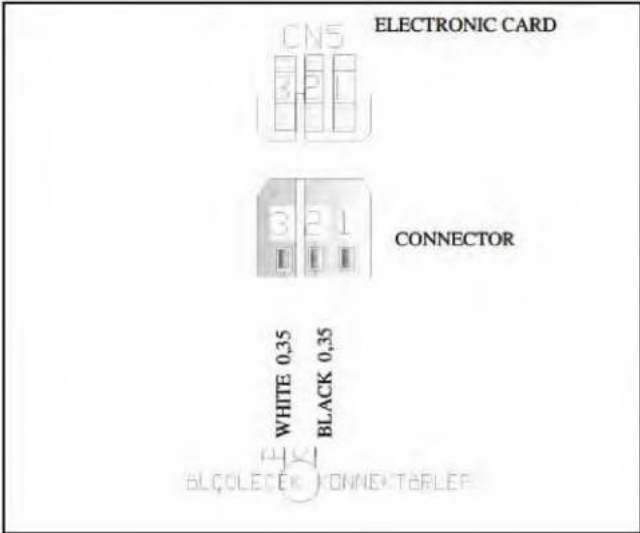

Above sketch shows the connectors of the rinse aid sensor on the electronic card.

From the component:

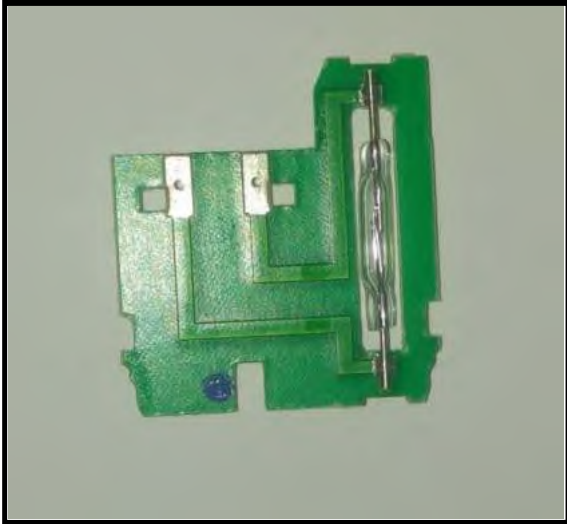
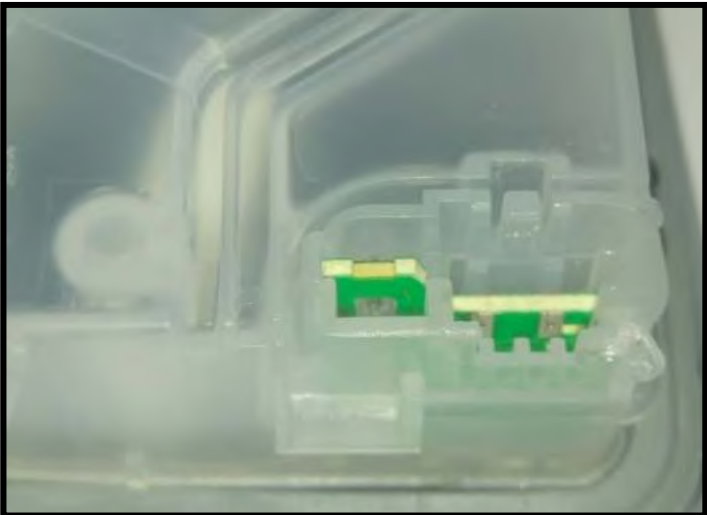

Probes of the tester should be applied on to the relatde connectors as shown on the pictures.

# ON/OFF SWITCH

It can't be measured from the electrical card.

	C	T	
DOOR SWITCH	CN2.9 - CN2.2 0 Ω	KN2.8 - KN2.10 0 Ω	Door is close

From the component:

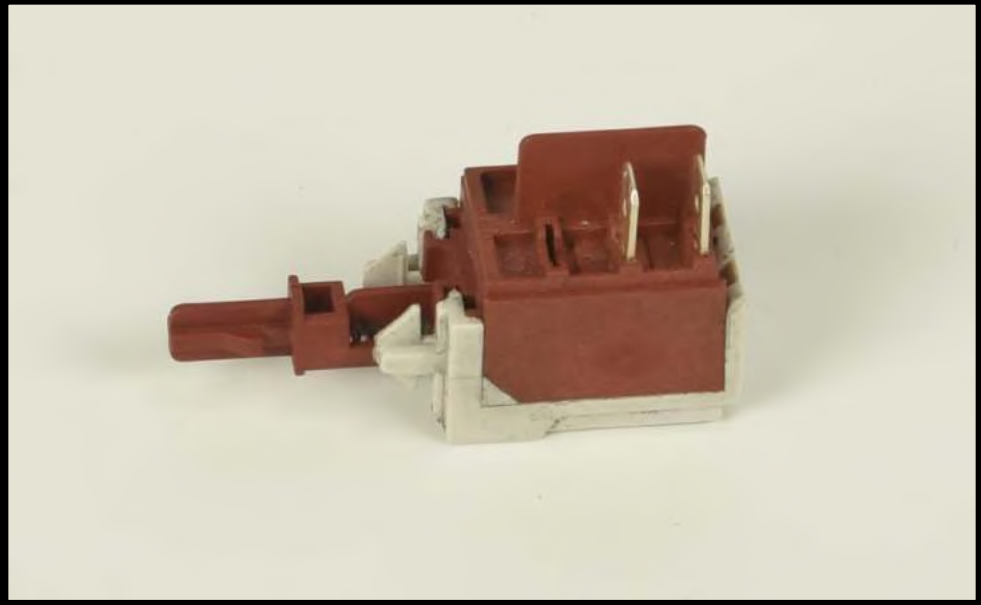

# DISASSEMBLY

**CAUTION!:** REMOVE ELECTRIC PLUG FROM THE SOCKET DURING THE DISASSEMBLY

## Top Plate

- a) Remove two screws that fix the top plate at the back.
- b) Push the top-plate back and pull it up.



## Plastic Kick Plate

- a) Remove two screws fixing plastic kick plate.



- b) Remove the plastic kick plate as it is shown in the picture.



## Side panels

Remove the screws fixing side panels



## Front Panel

a) Remove the screws as it shown in the picture.



b) Pull down the front panel after removing the screws.



## Kick Plate Sheet Iron

- a) Remove top plate, plastic kick plate and side panels.
- b) Remove the screws (4 screws) that fix the kick plate sheet iron.
- c) Pull it down as shown in the picture.



- To remove the side panel, remove the upper plastic hinge and then the above one and pull it up.



## Control Panel

- a) Remove 6 screws that fix control panel to the door inside sheet iron.
- b) Remove the control panel group carefully as shown in the picture

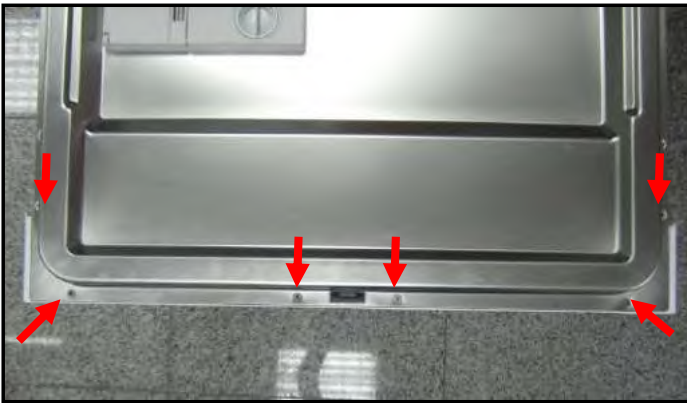

- c) Remove the cable connection plastic which fix cable harness to the control panel as shown in the picture.
- d) Remove the wires that are connected to control panel group.



**IMPORTANT WARNING!:** In case of control panel is needed to be disassembled, do not remove the control panel without removing the outer door metal sheet! Interventions on the control panel without removing the door outer metal sheet damage the cables and electronic card sockets, thus cause safety risk!

- c) Remove the cable tie plastic securing the harness to the control panel as shown in the picture
- d) Disconnect the cables attached to the control panel assembly

## Door Lock Group



- a) Remove control panel group
- b) Remove two screws that fix the door lock group.

## Dispenser

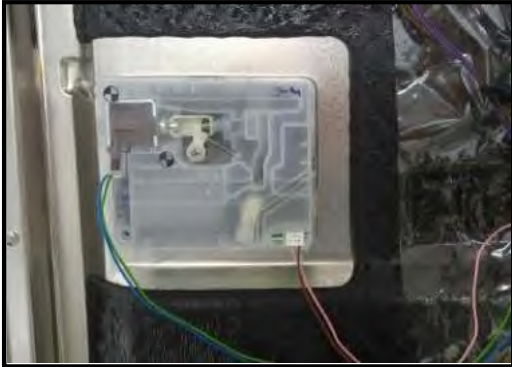

- a) Remove the front panel
- b) Remove the wire.
- c) Remove dispenser from inside door's hingers by using slotted screwdriver.  
Push and remove the dispenser.

## Door Inside

- a) Remove side panels.
- b) Remove Built-in Hinge Spring.



- c) Pull the door inside up as It is shown in the picture.
- d) Remove two screws that fix hinge movement sheet iron to the door inside.



## Air - break



a) Remove the left side panel of the machine.

b) Open machine's door

c) Rotate counterclockwise air-break nut and remove it.

d) Remove air-break's connections with salt cap as it is shown in the picture. (be careful about plastic hinges)



## Hose connection plastic



a) Remove left side panel.



b) By using flat tip screwdriver remove hose connection plastic's hinge from the basement as it shown in the picture

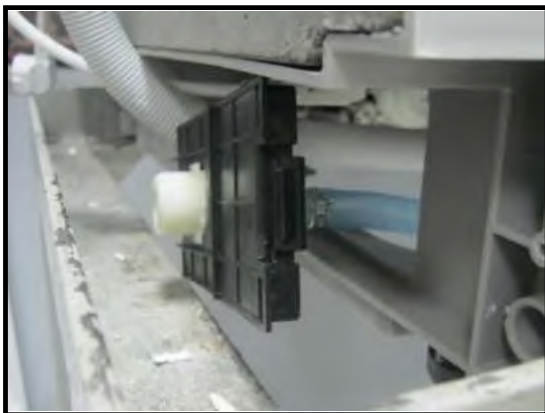

c) Push the hose connection plastic.

**Warning:** If you do not obey instructions while disassembly of the hose connection plastic it can be broken.

## Power cord

- a) Remove hose connection plastic.



- b) Remove the lower cover.
- c) Remove the wires that is between power cord and parasite filter.
- d) Remove the power cord.



## To access the components from in Front of the Machine



- a) Remove plastic kick plate iron sheet and basement front cover

## Regeneration valve

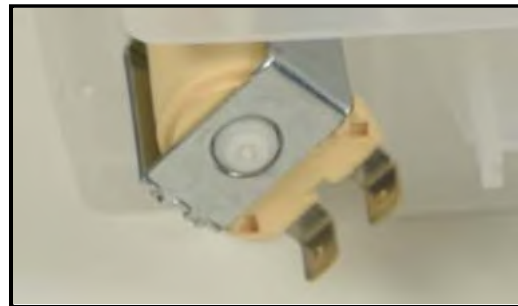

- a) Remove plastic kick plate and kick plate iron sheet.
- b) Remove the wires
- c) To remove regeneration Value rotate counterclockwise and pull it as it is shown in the picture.

## Drain pump



- a) Remove plastic kick plate and kick plate iron sheet
- b) Remove the wires.
- c) To remove the drain pump that fixes to the sump, rotate it an the direction of counterclockwise and pull.

## Access the components from the lower cover

a) Lay the appliance on the rear panel.



b) Remove lower cover from the places that are shown in the picture.



## Circulation pump

a) Remove lower cover from the places and measure the component.

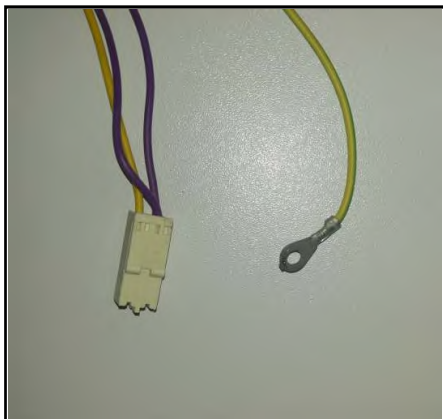

## Water softener



a) To remove salt cup cover, rotate it in the direction of counterclockwise

b) To remove salt cup nut, rotate it in the direction of counterclockwise.

c) Remove left side panel.

d) Derach the connections which are between water softener and air-break.

e) Remove lower cover.

f) Remove the hose that is between sump and salt camp.



## Parasite filter



a) Remove lower cover.

b) Remove one screw fixing parasite filter.

c) Remove wires.

d) Push parasite filter and remove it.

## Floater



a) Remove lower cover.



b) Remove two screws that fix floater as it is shown in the picture.



c) Remove the two floater hoses.

d) Remove the wire that is connected to the floater.

## Water Inlet valve

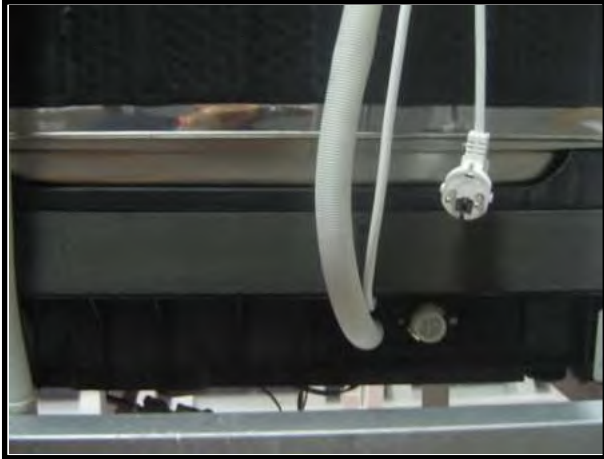

a) Remove lower cover.



b) Remove the wire that is connected to the water inlet valve.

c) Remove the clamp that connects water inlet valve and air-break as it is shown in the picture

To remove water inlet valve pull it back as it is shown in the direction of picture then release water inlet valve from the pins that is connecte to and rotate it in the direction of counterclockwise.



## Draining hose



- a) Remove the hose connection plastic.
- b) Remove lower cover.
- c) Remove the clamp that fixes draining hose to the sump
- d) Remove draining hose

## Lower basket



- a) Open machine's door.
- b) Pull the basket to yourself.

## Upper basket



- a) Open upper basket rail lock front.
- b) Pull the basket to yourself and remove it.



## The components that are inside the tub course, micro and metal filters

- a) Open the door.
- b) Remove lower basket
- c) To remove microfilter group rotate them in the direction of counter clockwise and pull them up as it is shown in the picture



- d) To remove microfilter group (course filter and micro filter ) pull them as it is shown in the picture.



- e) To remove the metal filter pull it up as it is shown in the picture.

